

W
I
N
T
E
R
B
R
O
S
E

T
U
T
O
R
I
A
L
S

BLENDER BASICS

The Making Of A **PUMPKIN**



By ZEAL

Table Of Contents

<i>Setup</i>	3
<i>Add Primitive</i>	4
<i>Basic Shape</i>	5
<i>Rounding Object</i>	9
<i>Fine Tuning</i>	11
<i>Color Shading</i>	12
<i>Smoothing</i>	13

End User License Agreement (EULA)

This tutorial is provided as-is with no warranties either expressed or implied. You may copy, share or distribute copies of this tutorial in its original form at no cost whatsoever to others. You may not modify or change it in any way. You may not sell it or include it in packages or collections that are for sell. You may not claim authorship in any form for this work. The author retains all copyright ownership.

Copyright © 2009, Zeal. All Rights Reserved.

Setup

You will need Blender version 2.4x or higher to complete this tutorial. You can get the Blender 3D Modeling software for FREE from:

<http://www.blender.org/>

It's time to create ourselves a pumpkin, experienced users of blender can skip this section. Let's start a new project with **File / New**. At the popup click "Erase All."

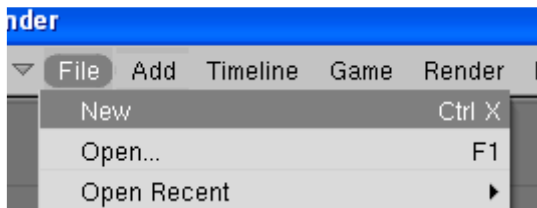

Starting New Project



Remove Old

With your mouse cursor over the 3D View window, press the "X" key to delete the default Cube that exists. When the popup question appears click on "Erase selected Object(s)".



Deleting Default Cube

Add Primitive

Let's add a new Cylinder object by clicking **Add / Mesh / Cylinder** on the menu bar, or pressing the **Spacebar** with your mouse cursor over the 3D View window.

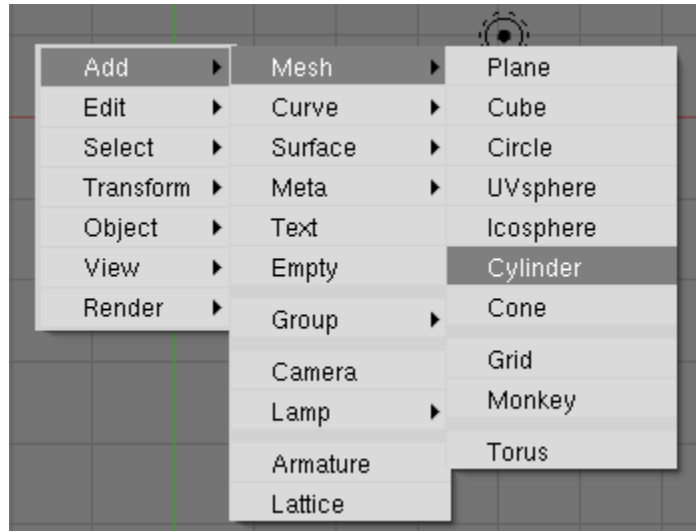

Add Objects Menu

Let's change some settings for our new Cylinder. Click the left-arrow on the **Vertices** bar until it reaches **24**. Leave the other settings at the defaults. Click the OK button.

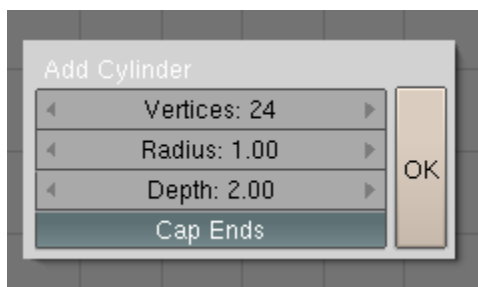

Settings for Cylinder

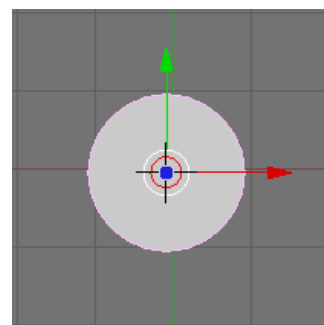

New Cylinder

Basic Shape

Once you have the Cylinder, we need to prepare for editing by clicking the **Mode** box along the bottom edge of the 3D View window and selecting **Edit Mode** or just by pressing the **Tab** key.

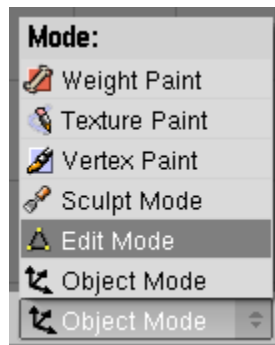

Mode Menu

You can zoom in on your Cylinder by rolling the Middle Mouse button with your mouse cursor over the 3D View window.

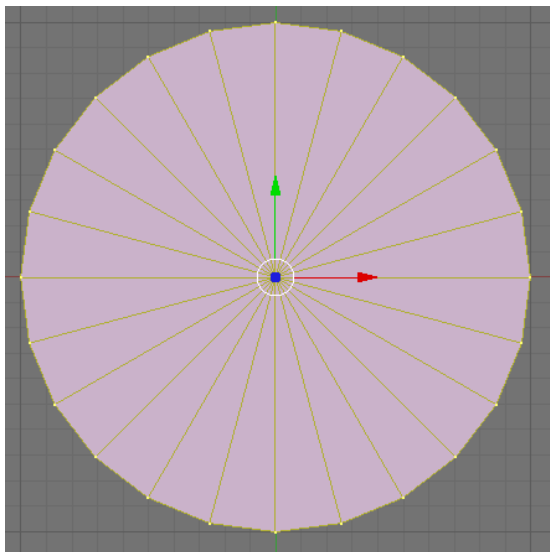

Zoomed View of Cylinder

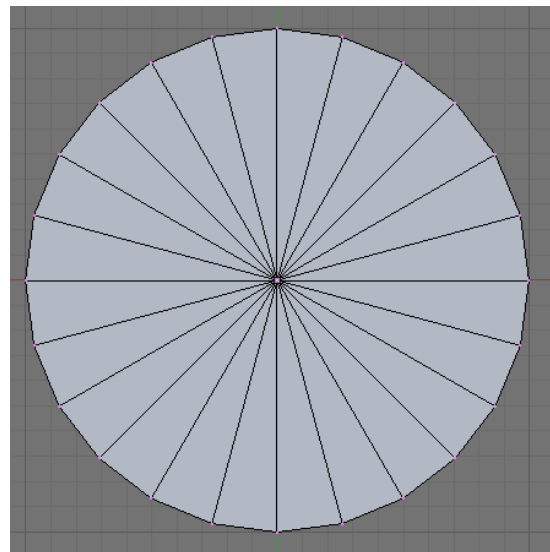

Unselect All

For new objects, the default is for the complete object to be selected. After entering edit mode, you will need to deselect all by pressing the “**A**” key with your mouse cursor over the 3D View window.

We will use **Box Select** by pressing the “**B**” key with your mouse cursor over the 3D View window to ensure we select vertices on both the bottom and top of the cylinder while editing the cylinder from the **Top View**. Start with the top-most vertex. The pattern we will use is to select one vertex and then going either direction skipping two then select one, as shown using the Top View (Numpad 7). Using Box Select, go around the top of the cylinder selected every third vertex.

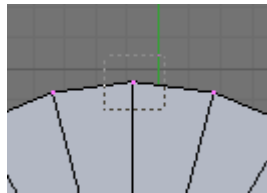

Box Select Box

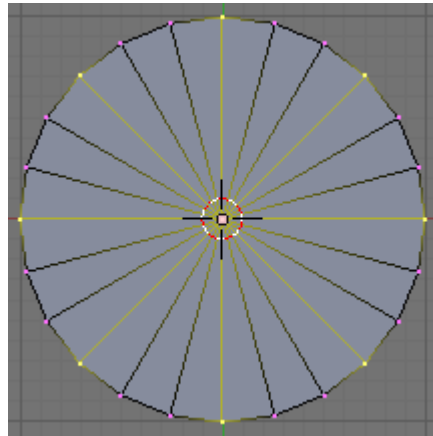

Top View

We need to ensure that the bottom vertices are also selected. You can go to Front View by pressing “1” on the Numeric Keypad (**Numpad-1**) or selecting **View/Front** from the 3D Viewing Window control bar. When finished, return to Top View by pressing **Numpad-7** or using the menu again with **View/Top**.

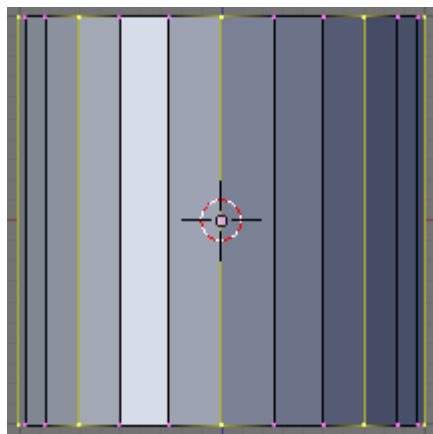

Side View

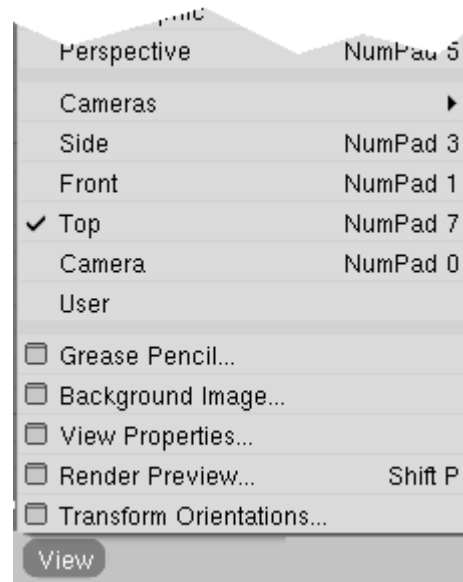

VIEW Popup Menu

Once the vertices are selected, we then scale them down a little bit by pressing the “S” key with your mouse cursor over the 3D View window. You can use the mouse to adjust it to look something like this.

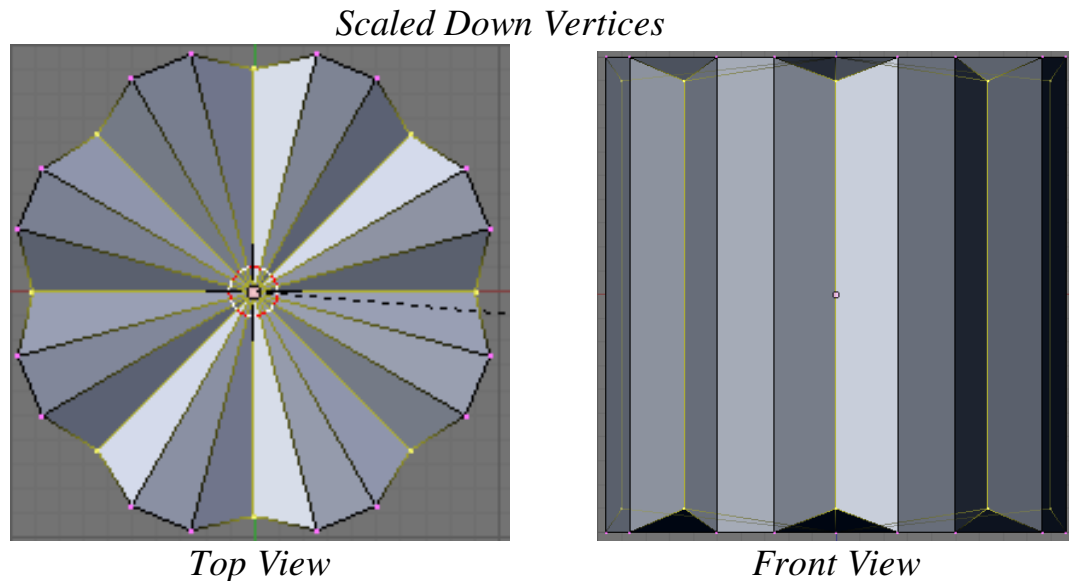

You can find these coordinates at the bottom left of the 3D View window.

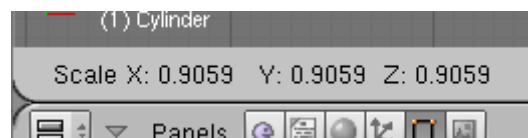

For you perfectionists, I actually scaled it down to about 0.9 X, 0.9 Y, 0.9 Z. If you would rather get more precise scaling than using the mouse cursor, then with your mouse cursor over the 3D View window press the “S” key followed by the direction you want to scale and type the exact scaling number (with decimal point) followed by the Enter/Return key.

For X: hit “S”, hit “X”, type “0.9”, hit “ENTER”

For Y: hit “S”, hit “Y”, type “0.9”, hit “ENTER”

For Z: hit “S”, hit “Z”, type “0.9”, hit “ENTER”

So far so good, but we need to cut the pumpkin to give it some shape. Go to the Front View (Numpad 1 or View/Front) so we can further refine our object's shape. We will be using "Ctrl-R" to insert some **horizontal divisions** in our object. We do not want to make them vertical.

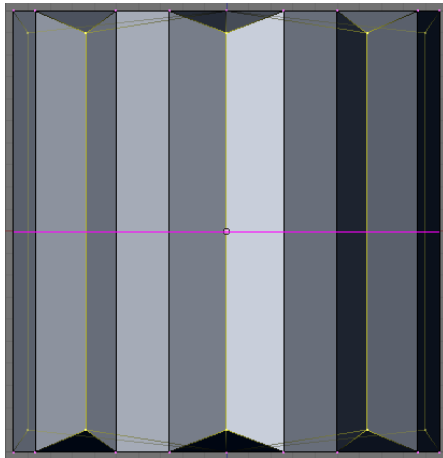

Horizontal Divider

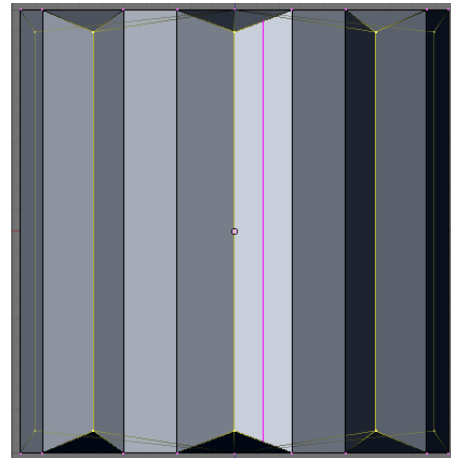

Vertical Divider

Hit "**Ctrl-R**" with your mouse cursor over the 3D View window, move your cursor over the object until you get the horizontal divider line then click once on the object. Click again to move the line up to make the top marked divider shown below. Repeat this again to create the bottom divider. Press "**A**" to deselect all.

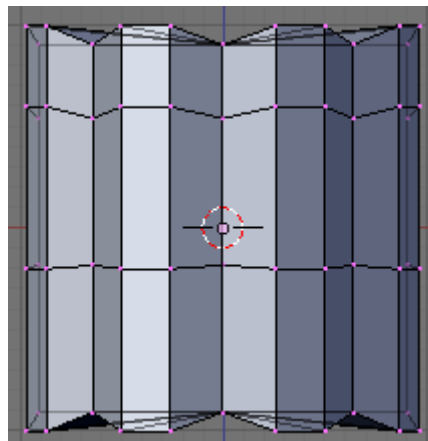

You can configure the marks any way you want because pumpkins aren't always the same, which makes this very flexible. If you have what I have or something near it, you are doing very well.

Rounding Object

Box Select the top portion of the object and Scale it down, then repeat for the second and bottom portions. Don't forget to Deselect All in between. You can Scale any of the marks the way you like it to get something like this or any way you like, it doesn't have to be perfect. I made the top part a little smaller scaled than the bottom, but it really doesn't matter.

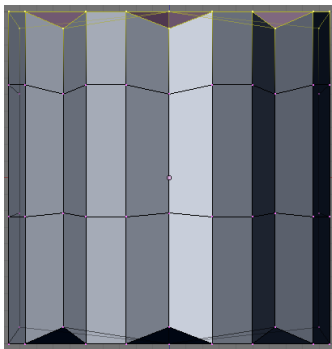

Top Portion

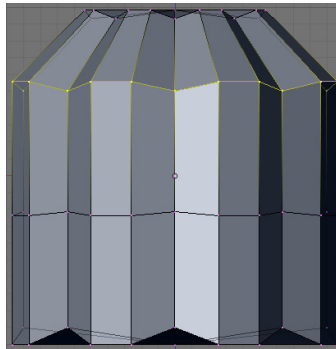

Second Portion

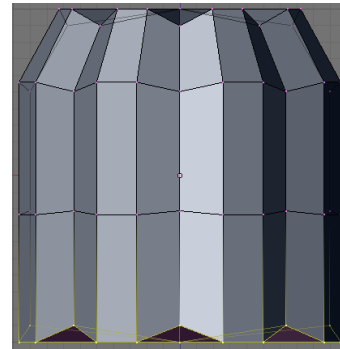

Bottom Portion

For more precision use the following for the top and bottom portions:

TOP PORTION

Use "0.5" for X, Y and Z

SECOND PORTION

Use "0.9" for X, Y and Z

BOTTOM PORTION

Use "0.7" for X, Y and Z

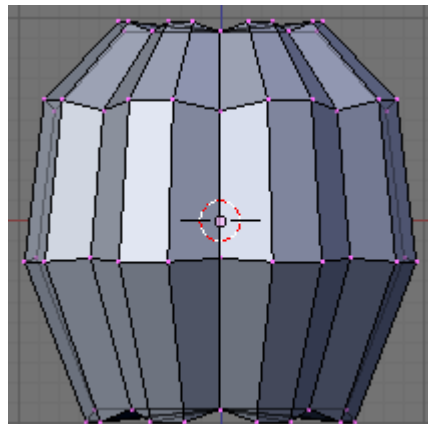

Scaled at Top and Bottom

One more step until we get a really good looking pumpkin. A pumpkin isn't flat on top and bottom so let's fix that. Go to Top View and Box Select the vertex in the middle of the pumpkin. We want to use Box Select so that the vertex in the Bottom Center is also selected.

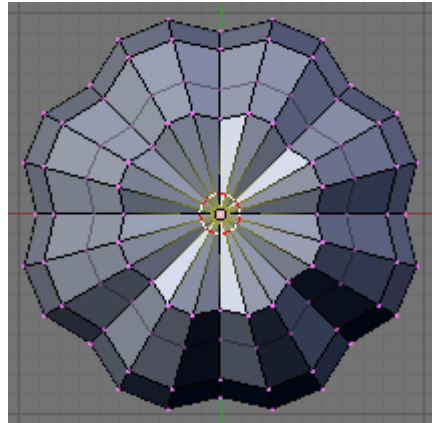

Middle Vertices Selected

Go to front view and scale it to something a little deep as it will alter when we smooth it out.

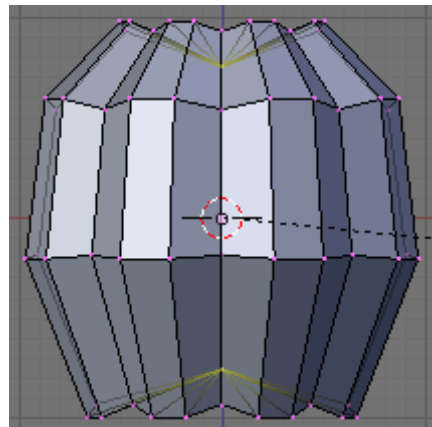

Final Shape

Before we go any further, make sure you have something similar to this.

Fine Tuning

Go to **Object mode** and make sure you are in the **Editing** button window.

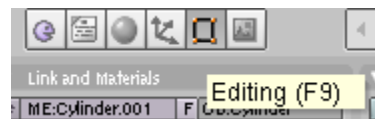
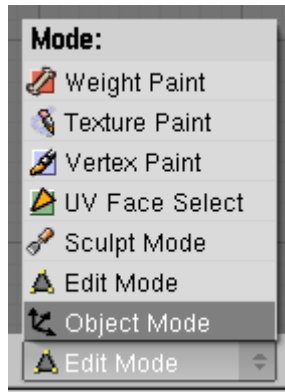

Make sure the cylinder is selected and click the **Add Multires** button in the Multires section, then click the **Add Level** button three times.

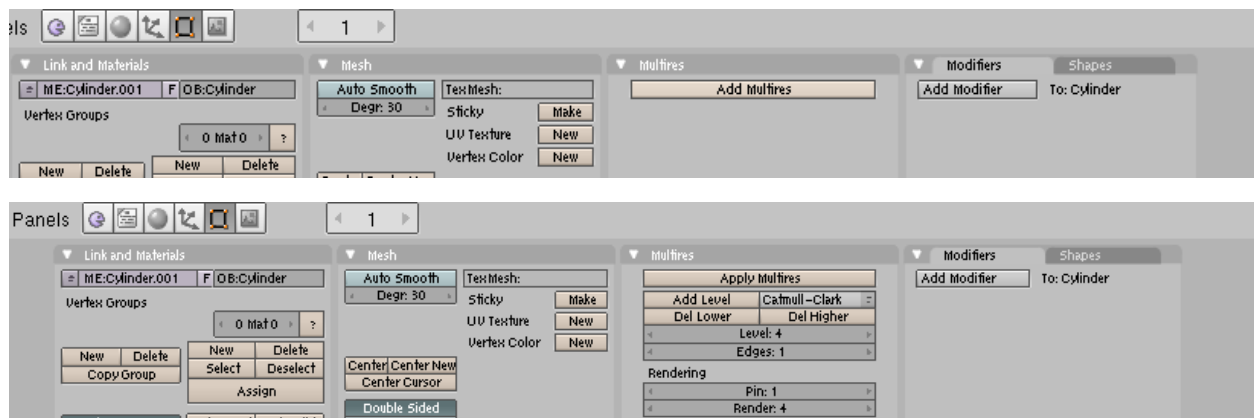

To finish it off and make things more permanent click the **Apply Multires** button.

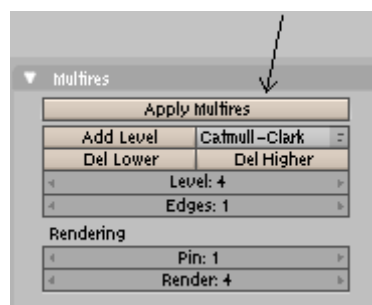

Last Step

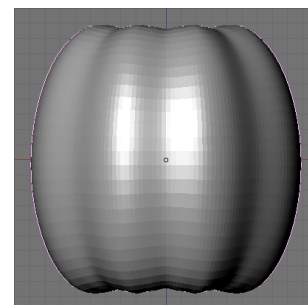

Final Shape

Color Shading

To complete it, it needs to be obviously orange. Let's go to the **Shading** button window click **Add New** in the Links and Pipeline section..

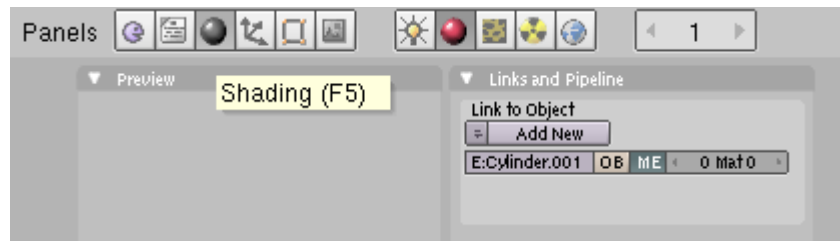

Let's change its color. You can choose whatever color you like. Just click the first shading box in the Material tab, click the horizontal color bar for an orange shade, and then click on how light or dark you want it in the upper box.

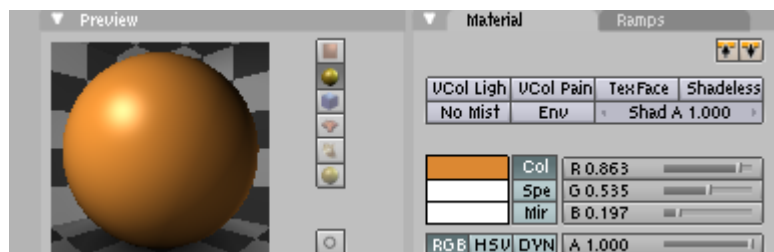
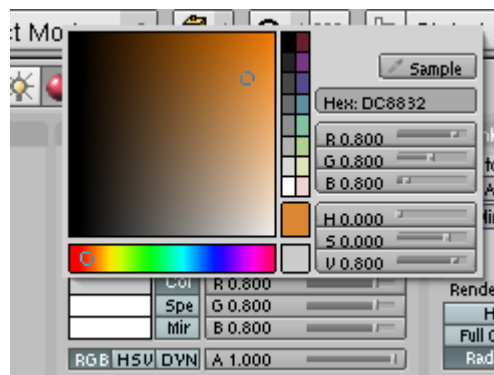
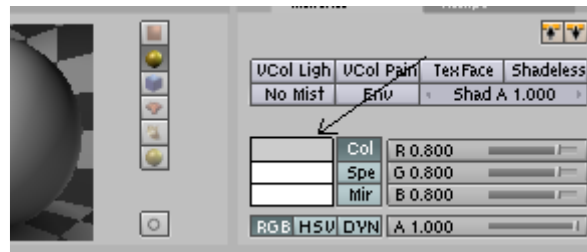

Smoothing

Abra Kadabra! You've got yourself a pumpkin.

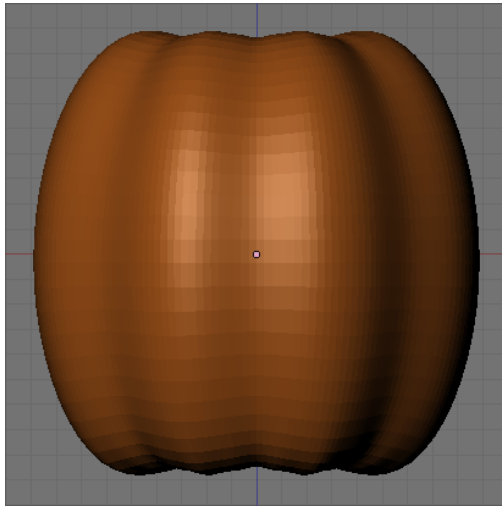

Final Color

You may see that it's a little jagged and say to yourself maybe I should add more Multires to smooth it out. That would not be a good idea for a couple reasons, but let me break it down. Adding the least amount of multires is best because the more multires you have, the more vertices and faces you are making which in turn makes it slower to render and even slower edit, sometimes impossible.

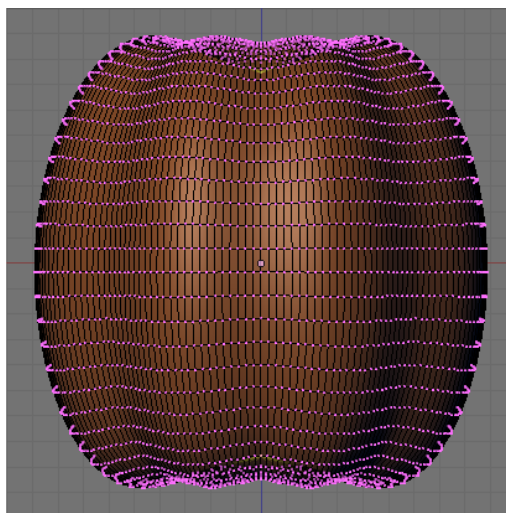

All Vertices Shown

All you have to do is go to the **Editing** button window, make sure the object is selected and click **Set Smooth** in the Link and Materials section.

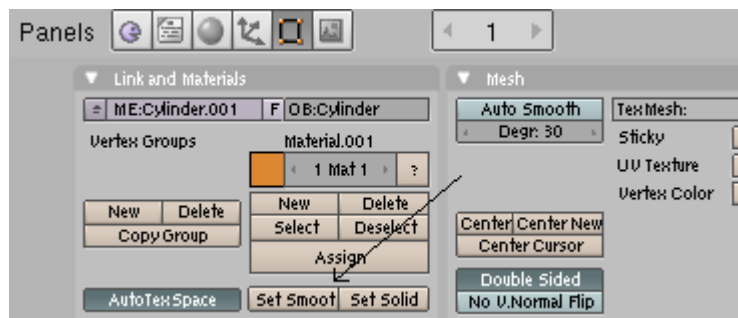

You are done, well sort of. All you need to do is add the little touches like a stem at the top and if you are feeling in the mood maybe a leaf to go along with it, but here is the finished product:

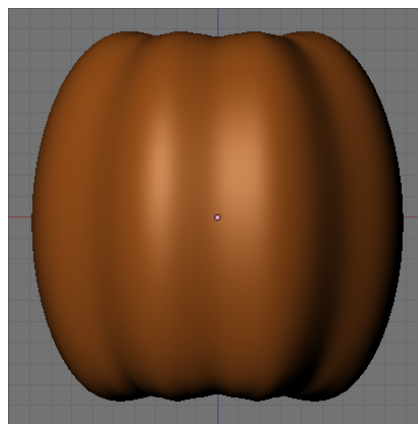

Final Pumpkin

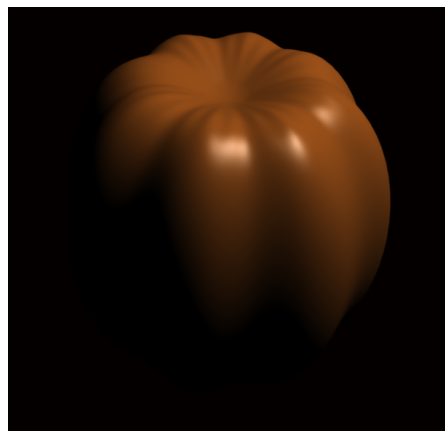

Rendered Pumpkin